

# GREENHOUSE COOLING

*D.H. Willits  
Biological and Agricultural Engineering Department  
North Carolina State University*

Reprinted from the North Carolina Flower Growers' Bulletin Vol. 38, No. 2

**Cooling is a fundamental requirement of almost any greenhouse operation, yet the process is not very well understood by most growers (and some researchers).**

**All surfaces in the greenhouse lose heat through radiative and convective cooling; however, most of the heat loss comes from the canopy and the ground.**

**Plants evaporate water through the process of transpiration, which is controlled, in part, by openings (stomata) in the surfaces of the leaves.**

Cooling is a fundamental requirement of almost any greenhouse operation, yet the process is not very well understood by most growers (and some researchers). At NCSU, we have conducted several cooling studies over the past few years and the results have given us some insight as to what is going on.

Heat loss from a greenhouse can be either good or bad, depending upon the temperature. During periods of cold weather, heat loss is undesirable and steps are taken to minimize it wherever possible. During periods of hot weather, heat loss is essential to the cooling process and should be maximized, if at all possible.

The fundamental mechanisms available for cooling a greenhouse are radiation, convection and the evaporation of water (Figure 1).

All surfaces in the greenhouse lose heat through radiative and convective cooling; however, most of the heat loss comes from the canopy and the ground. Further, only the canopy and the ground

lose heat through the evaporation of water.

Radiative cooling is generally a minor factor during warm weather (the period of prime interest) but convection and evaporative cooling are major factors and are, in fact, inter-related. If convection were not present, the air around the leaf would soon become saturated and transpiration would effectively cease. One way to relate to this is to compare it to a sweat box (Figure 2). If you cannot get rid of the water no cooling will take place.

## Transpiration

Plants evaporate water through the process of transpiration, which is controlled, in part, by openings (stomata) in the surfaces of the leaves. Generally speaking, the stomata are completely open during daylight hours, allowing moisture to evaporate at a rate governed by the flow of air over the leaves (convection), and the content of water in that air. In a full greenhouse, canopy transpiration is generally the largest single fac-

**Figure 1.** The basic mechanisms for cooling are radiation, convection and water evaporation (or transpiration).

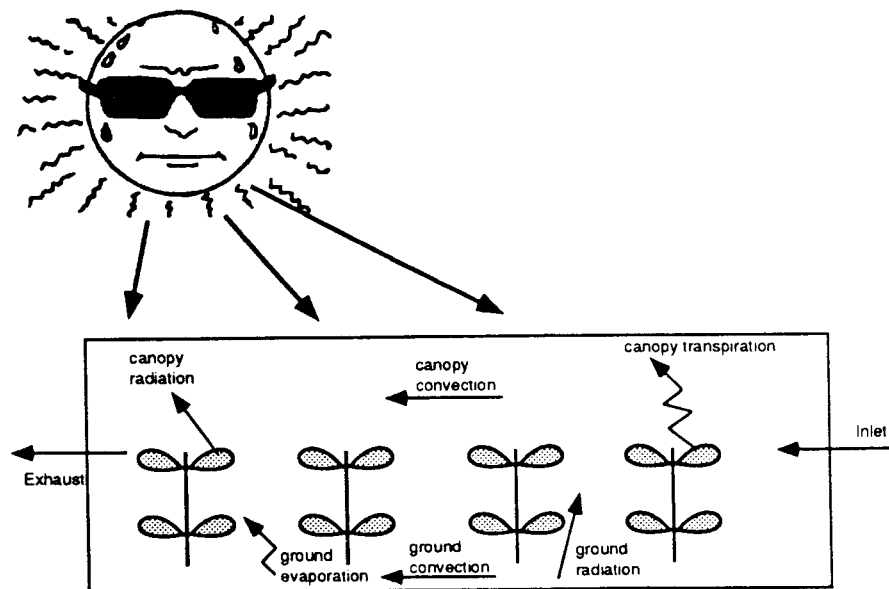

**Figure 2.** A closed greenhouse can quickly become a sweat box.

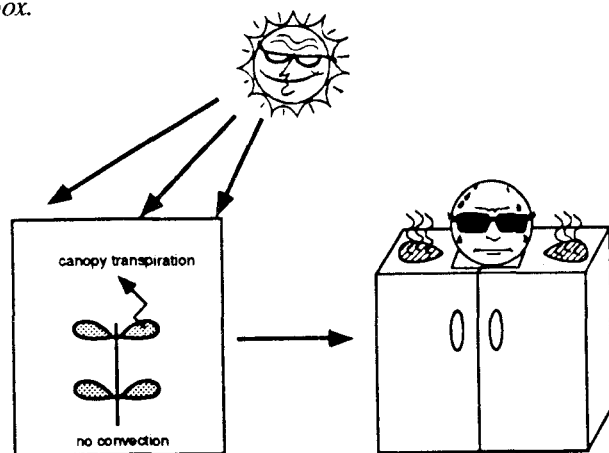

Table 1 shows that for outside temperatures of 90°F, evaporative pads only provide exit temperatures about 3°F below that produced by exhaust fans alone. Average temperatures are much lower, however, because the temperature at the inlet end is substantially lower than that without pads. In this part of the country, fogging would be expected to perform no better than evaporative pads, although the temperature difference from end-to-end would probably be somewhat less.

**Cooling equipment available for greenhouses is generally limited to multiple speed exhaust fans installed in one end of the greenhouse with evaporative pads installed at the other.**

**Empty Houses.** In an empty, or nearly-empty, house (a house full of immature plants or partially rooted

cuttings affecting temperature, with ground evaporation coming in a distant second. In an empty, or nearly empty, greenhouse the lack of transpiration can make it very difficult to control temperature.

cuttings qualifies as a nearly empty house) a different approach may be required. Since very little moisture is available for evaporation inside the house almost any that can be evaporated will affect temperatures greatly. With exhaust fans only, exit temperatures might be expected to reach 110°F on a 90°F day (Table 2). Evaporating water at the inlet of the house (as with evaporative pads) will help, but the temperature will still rise rapidly as the air moves through the house, because little additional water is available for evaporation. Exit temperatures can reach 100°F.

**Cooling Alternatives**

Cooling equipment available for greenhouses is generally limited to multiple speed exhaust fans installed in one end of the greenhouse with evaporative pads installed at the other. Fogging systems are also available, but should be used with reservation, depending upon the operation.

**Implementation of any cooling scheme should be based, in part, on the amount of transpiration present and, in part, on the expected outside conditions.**

**Full Houses.** Implementation of any cooling scheme should be based, in part, on the amount of transpiration present and, in part, on the expected outside conditions. In a full greenhouse (e.g., mature chrysanthemums on the benches with hanging baskets over the aisles), the crop evaporates large quantities of water into the air and little, if any, additional evaporation can be accomplished, especially if outside conditions are humid as they generally are in this part of the country.

**Table 2.** Estimated inlet and exit temperatures for a nearly empty greenhouse on a 90°F day.

System type	Inlet temp.	Exit temp.
Exhaust fan	90°F	110°F
Evap. pad	78°F	100°F
Fog + fan	80°F	90°F

**Table 1.** Estimated inlet and exit temperatures for a full greenhouse on a 90°F day.

System type	Inlet temp.	Exit temp.
Exhaust fan	90°F	93°F
Evap. pad	78°F	90°F
Fog + fan	80°F	90°F

Fogging is probably the best solution where little transpiration is available, even in this area of the country. Performance would be expected to approximate that of evaporative pads used with a full crop. Fogging should be considered for rooting and seedling houses, houses with young plants and houses with small plants (i.e., houses full of small 4" material such as African violets.).

**System Selection**

Table 3 presents some of the current design recommendations for greenhouse cooling. Typi-

**Fogging is probably the best solution where little transpiration is available, even in this area of the country.**

**Table 3. Some recommendation for greenhouse cooling systems.**

System type	Airflow (chgs/min)	Pad velocity (fpm)	Water flowrate (gpm/ft)*	Water bleedrate (gpm/1000 cfm)	Sump capacity (gal/sq.ft.)
Aspen pad	1 to 1.5	150	0.30	0.05	0.50
4" pad	1 to 1.5	250	0.50	0.05	0.75
6" pad	1 to 1.5	350	0.75	0.05	1.00
Fog	1 to 1.5		0.03-0.04 gph/sq.ft.		

\*Water flowrates for evaporative pads are per lineal foot of pad. Water flowrates for fogging systems are per square foot of floor area.

To determine the quantity of air that needs to be moved we must estimate the volume of the house.

cally, for this area if the country, an air flow of 1 to 1.5 air changes per minute should be provided via exhaust fans, regardless of any additional method of cooling used. Evaporative pads, if used, should be sized so that the air velocity through them ranges from 150 fpm for aspen pads to 350 fpm for 6" corrugated pads. Water flowrate for evaporative pads is not critical, but should be above the minimums listed. Most of the water is simply recirculated and only a small portion (approximately equal to the bleedrate) is evaporated into the air. The excess water is used to insure that the pads remain fully wet. Water flowrates for fogging systems should be roughly the same for a given house as the recommended bleedrate for evaporative pads.

**Example.** As an example, consider a 30 ft by 110 ft Quonset house located in North Carolina (Figure 3). Let's assume that it will generally contain a full crop during periods of the year when cooling will be required, so let's choose an evaporative pad as the supplementary cooling method.

where L is length of the house, 3.1416 is pi and W is the house width. Using our numbers,

$$\text{Vol} = \frac{0.5 \times 110' \times (3.1416 \times 30' \times 30')}{4}$$

therefore, Vol = 38,882 ft<sup>3</sup>.

Air flow for this greenhouse, then, should be somewhere between 39,000 and 59,000 cfm, depending upon whether we choose 1 air change per minute or 1.5 air changes per minute. The primary deciding factor should be the expected outside temperatures and the potential damage to the crop if inside temperatures rise too high. For this area of the country, 1.5 air changes per minute should be used if you plan to grow throughout the summer, especially if the crop will be in the flowering stage (the most temperature sensitive stage for flowering crops) during the warmest weather or if a temperature sensitive crop (subject to heat delay) is to be grown.

The primary deciding factor should be the expected outside temperatures and the potential damage to the crop if inside temperatures rise too high.

To determine the quantity of air that needs to be moved we must estimate the volume of the house. We do that by assuming that the cross-section of the house is semi-circular (which it really isn't--but it's very close). This allows us to approximate the volume as that of 1/2 that of a cylinder with a diameter equal to the width of the house. This gives:

$$\text{Vol} = \frac{0.5 \times L \times (3.1416 \times W^2)}{4}$$

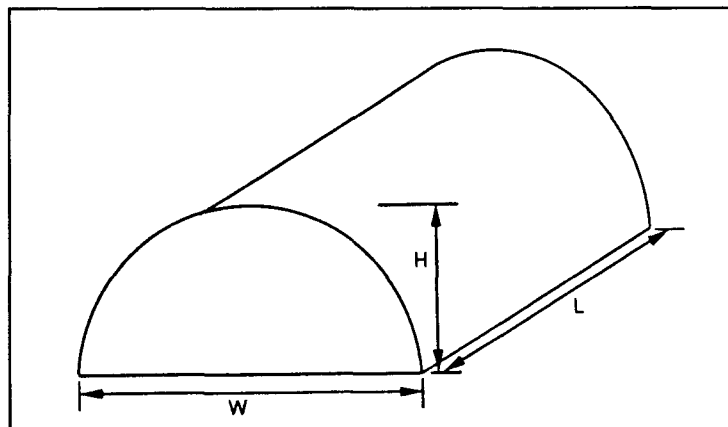

Figure 3. A typical Quonset-style greenhouse.

From the fan charts supplied by the exhaust fan manufacturer, a 48", 1 hp fan should supply 19,600 cfm at 0.1" of water static pressure (use the 0.1" rating if you will be using evaporative pads, 0.05" rating if not). Two such fans will provide the lower airflow while three will be required if the higher airflow is desired.

Using the recommended pad velocities from Table 1, a 4" thick pad would require:

$$\text{Area} = \frac{(39,200 \text{ cfm})}{(250 \text{ fpm})} = 157 \text{ ft}^2$$

if two fans are selected and:

$$\text{Area} = \frac{(58,800 \text{ cfm})}{(250 \text{ fpm})} = 235 \text{ ft}^2$$

if three fans are selected. As a rule, 235 ft<sup>2</sup> would not be available in a 30 ft wide Quonset house. An alternative, if we were to use three fans, would be to use a 6" pad, which would require only 168 ft<sup>2</sup>:

$$\text{Area} = \frac{(58,800 \text{ cfm})}{(350 \text{ fpm})} = 168 \text{ ft}^2$$

For the remainder of this example, calculations will be based on using only two fans totaling 39,200 cfm and a 4"-sized pad totaling 157 ft<sup>2</sup> of pad area. A 4" pad sided for two exhaust fans would require about 28 ft of pad:

$$\frac{157 \text{ ft}^2}{5.6'} = \text{about } 28 \text{ ft}$$

A 4" pad requires 0.50 gpm/ft of pad run, so the water flow rate delivered to the pad should be:

$$(0.5 \text{ gpm/ft}) \times (28 \text{ ft}) = 14 \text{ gpm}$$

The bleedrate (water drained off from the pipe delivering water to the pad to remove excess salts) needs to be added in prior to pump selection:

$$(0.05 \text{ gpm/1000 cfm}) \times (39,200 \text{ cfm}) = 2 \text{ gpm}$$

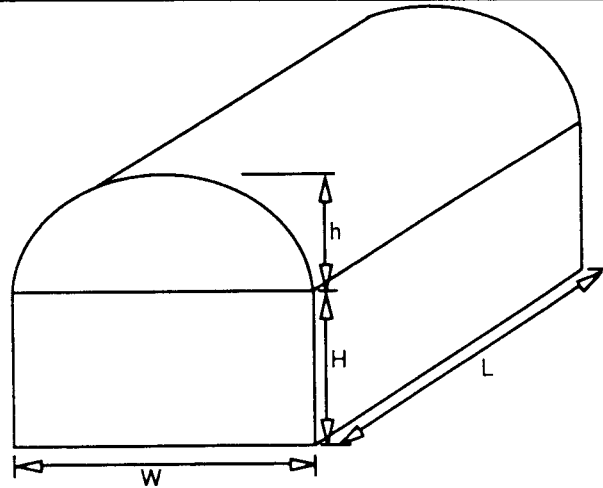

Figure 4. A typical section of gutter-connected raised Quonset greenhouse.

This gives us a required water flowrate by the sump pump of:

$$\text{Water Flow} = 14 \text{ gpm} + 2 \text{ gpm} = 16 \text{ gpm}$$

The sump pump should then be sized to provide 16 gpm at a head of about 10 ft.

Calculating the sump capacity required for the 4" pad gives:

$$\text{Sump Capacity} = (0.75 \text{ gal/ft}^2 \text{ pad}) \times (157 \text{ ft}^2) = 118 \text{ gallon capacity required}$$

In the above calculations we approximated the volume of a quonset house as that of 1/2 of a cylinder of width W and length L. The volume of gutter connected raised Quonset houses (Figure 4), must be approximated differently.

For each section of width W, gutter height H, gutter-to-peak distance h and Length L, we can calculate the volume of the lower section as a rectangular box (a hexahedron):

$$\text{Lower Volume} = H \times W \times L$$

We can approximate the volume of the upper section by assuming the circular arc can be represented by assuming the circular arc can be represented by a triangle with base W and height h, giving the volume of the triangular box (a pentahedron) section as:

$$\text{Upper Volume} = 0.5 \times h \times W \times L$$

The volume of the entire bay can then be approximated by adding the upper volume to the lower volume. For multiple bays, just multiply volume of one by the number of bays.

The bleedrate (water drained off from the pipe delivering water to the pad to remove excess salts) needs to be added in prior to pump selection.